

VAN DER VALK

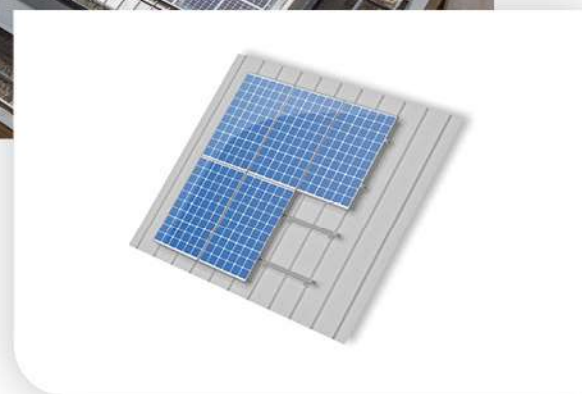

Installation manual



ValkPitched Standing Seam

Version: v1.3

Date: 19-04-2023

Table of contents:

Table of contents	Page 01
Disclaimer and General installation guidelines	Page 02
Recommended tools	Page 05
Required materials for Pitched roof - Standing seam [Clamp]	Page 06
Overview standing seam types	Page 07
Mounting 'round' standing seam clamp	Page 08
Mounting standing seam straight clamp	Page 09
Mounting aluminium profiles	Page 10-11
Coupling aluminium profiles	Page 12-13
Mounting end clamps	Page 14-15
Mounting panel clamps (middle)	Page 16
Cable clamps	Page 17-18
Mounting optional products	Page 19-20

VAN DER VALK



Disclaimer

This installation manual needs to be stored for future use. For project specific guidelines and recommendation it is required to use this document in conjunction with the "Project report" generated by the ValkPVplanner. The instructions provided in this Project Report must be strictly observed at all times.

The content of this installation manual has been carefully compiled. Van der Valk Solar Systems does not accept any liability for the correct use of this document. Van der Valk Solar Systems hold the right to update the content of this document without further notice. Please check the website of Van der Valk Solar Systems (www.valksolarsystems.com) for the most recent version of this document.

For the warranty conditions of your installation, please contact your supplier. Further we refer to our General Terms and Conditions, that are available upon request.

General installation guidelines

General

- During installation of the solar mounting system, the instructions and safety precautions presented in this installation manual must be followed carefully. As also stated in the General terms and Conditions of sale and delivery of Van der Valk Solar Systems B.V., non-compliance with the installation guidelines in this document means that the customer can no longer invoke any warranty and Van der Valk is no longer liable for any form of damage.
- The information, comments and advice in this document are binding. Van der Valk Solar Systems reserves the right to update this document without further notice.

Safety

- The installation of the mounting system must be carried out by qualified technical personnel.
- Omitting parts may negatively affect performance and is therefore not allowed.
- Avoid carrying out installation work during bad weather conditions, especially in case of strong winds and a wet (slippery) roof surface.
- During installation work on the roof, always use fall protection and, if necessary, work with safety nets and roof edge protection.
- Always wear appropriate protective clothing and gloves when carrying out the installation work.
- Follow the guidelines in the publication "Health & safety in roof work".

Environmental factors

- High neighbouring buildings or objects, such as windmills, can affect the wind pressure. In these cases, advice should always be obtained from Van der Valk Solar Systems before installation can take place.
- If during the installation it is determined that the project data and/or environmental factors do not fully correspond to the project report, the project must always be re-calculated first.
- In coastal areas, the system should be placed at least 500 meters from open water to prevent accelerated corrosion by the action of salt water. When buildings are present between the open water and the roof, a minimum distance of 250 meters from open water may be maintained.

Standards and regulations

VAN DER VALK



- For correct and safe installation and use of the solar mounting system, always observe the applicable standards and regulations:
 - EN 1990: Basis of structural design
 - EN 1991-1-3: General actions: snow loads
 - EN 1991-1-4: General actions: wind loads
 - IEC 60364: Electrical Installations for Buildings
 - IEC 62305: Protection against lightnings
 - EN 50110: Operation of electrical installations
 - Working Conditions Act and Safe Working Conditions Regulation

Stability and condition of the roof and roof covering

- The roof pitch should be less than 5 degrees for flat roof systems and between 5 degrees to 75 degrees for pitched roof systems.
- The condition of the roof must be checked upfront for sufficient strength to bear the weight of the mounting system including PV panels ballast and wind and snow loads. Make sure that the load reserve of the roof is not exceeded anywhere.
- Check the stability of the roof and adjust the roof/construction where necessary.
- Check prior to installation whether the roof covering and/or insulation is suitable for the pressure and thermal expansion of the solar mounting system. The maximum pressure is shown in the project report of the ValkPVplanner or can be requested at Van der Valk Solar Systems.
- Bulging of the roof membrane should be prevented. This can lift the solar mounting system and can cause displacement of the mounting system or ballast. It is the installer's responsibility to prevent the roof membrane from bulging.
- Factors such as overhead cranes, seismic activity and others that affect the stability of the roof and/or building can affect the installed solar mounting system. Van der Valk Solar Systems does not take these factors into account, unless confirmed in writing.
- The roof surface on which the solar mounting system is to be installed must be clean, dry and flat.
- The roof height may not exceed 25 meters in case the project has been calculated in the ValkPVplanner must be corresponding to the roof height in the project report. For installations on roofs higher than 25 meters, Van der Valk Solar Systems should always be contacted in advance.

Roof zones

- When installing the solar mounting system, always take the applicable roof zones according to EN1991-1-4 into account. Placing solar panels in the edge zone of the roof (the distance measured from the roof edge, which is equal to 1/5 of the building height) is only possible if this has been explicitly taken into account in the calculation.
- It is possible to position panels in the edge zone of the roof in the ValkPVplanner (calculation software), on the basis of which the required additional ballast or fixation points are automatically calculated. This can only be done using "Satellite" or "White Map" design mode. The edge zone is automatically calculated by the ValkPVplanner, based on the roof height and building circumference, in accordance with the applicable regulations. In case the design mode "Simple mode" is used, the calculation always assumes that the solar panels are in the middle zone of the roof only.
- In case solar panels on the ValkPro+ system are fully or partially placed in the edge zone of the roof, it is mandatory to use side plates.
- ValkKITS (ValkBox3, ValkDouble, ValkTriple, ValkQuattro) can only be placed in the middle zone of the roof. Placing these systems in the edge zone of the roof is not allowed.

Dilatations

- The maximum allowed dimensions of a coupled mounting system is a 30 meters in the aluminium direction and 60 meters in the steel direction. The maximum dimensions are based on the thermal expansion in case of a maximum temperature difference (Delta T) of 70 degrees Celsius.
- The coupled mounting system must not be placed over a gutter or ridge. In the mounting system is place over a gutter or ridge, the system must be split (dilatation).
- When using the extra wide panel support feet for ValkPro+ with ballast, different dilatation rules apply: in such installations the coupled system may be a maximum of 30 meters in the steel/roof carrier direction and 15 meters in the aluminium direction.

Solar panels

- It is the responsibility of the installer to determine in advance whether the selected solar panel is suitable for the mounting system in terms of dimensions and pressure loads. The calculated loads on the solar panel are shown in the project report of the ValkPVplanner or are available on request at Van der Valk Solar Systems.

Cable management

- In order to create a sound and durable electrical connection between the solar panels, it must be ensured that the cables from the junction box have sufficient length and thus do not cause any mechanical stress on the cable glands. Take into account thermal expansion and contraction of cables and the mounting system.
- Cables and connectors must be kept away from sharp and/or abrasive parts and the roof surface by using sufficient and appropriate cable clamps and cable baskets.

Disassembly and Removal

- Components of the solar mounting system can be easily and completely disassembled at the end of their service life and separated for recycling. The systems only contain nut and bolt, screw and click connections, so nothing is glued or welded. All materials are fully recyclable. Disposal of the components always in accordance with the locally applicable laws and regulations.

Required tools



Cordless drill



Socket 10-13mm

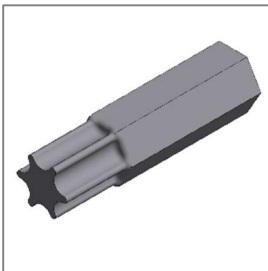

Torx bit T-30
(789530)

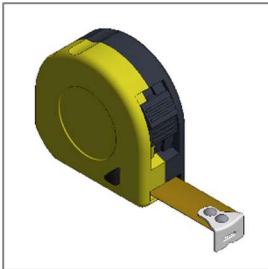

Measuring tape

Materials for installing Pitched roof - Roof tiles [Clamp]

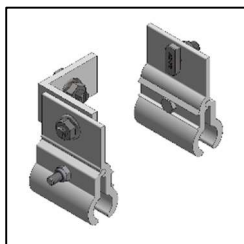

Round standing seam clamp
(72.77.95) - Landscape
(72.77.96) - Portrait

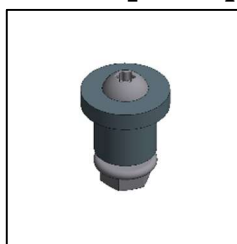

Plastic panel alignment pins
(733020)

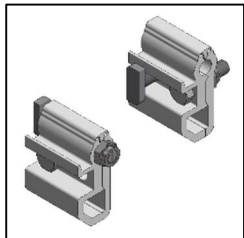

Straight standing seam clamp
(72.78.00) - Portrait
(72.78.01) - Landscape

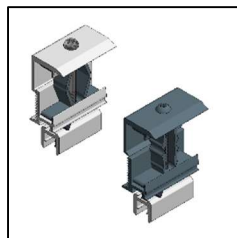

Aluminium end clamp 28-50mm
(721552) - Blank
(721552ZW) - Black

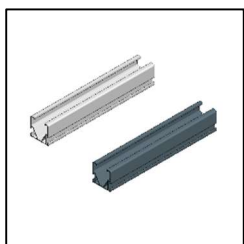

Aluminium side++ profile
(7017.....*)
*see table

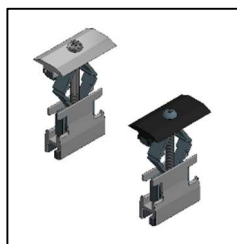

Aluminum mid clamp 28-50mm
(721550) - Blank
(721550ZW) - Black

Profile length	Art no. Blank profile	Art no. Black profile
1220 mm	701701220	
2370 mm	701702370	701702370ZW
3520 mm	701703520	
4670 mm	701704670	
5820 mm	701705820	

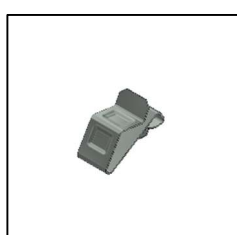

Ss cable clamp small
(732001)

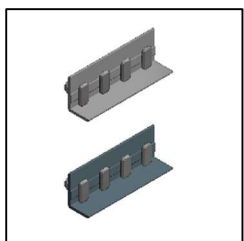

Coupling piece side++ profile
(724863) - Blank
(724863ZW) - Black

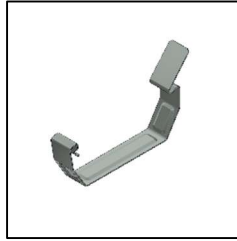

Ss cable clamp large
(732005)

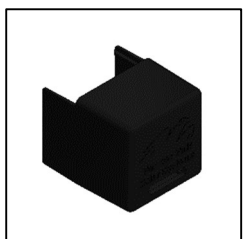

Plastic end cap for side++ profile
(739052)

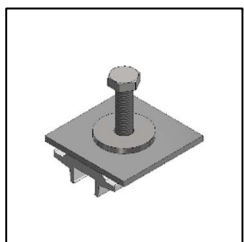

Optimizer clamp for side++ profile
(774223)

Overview standing seam types

Because there are different types of standing seam roofs there are different mounting clamps available for certain occasions. Down below is shown which mounting clamps can be used for certain standing seam roofs. If the standing seam type is not shown below contact Van der Valk Solar for a fitting solution.

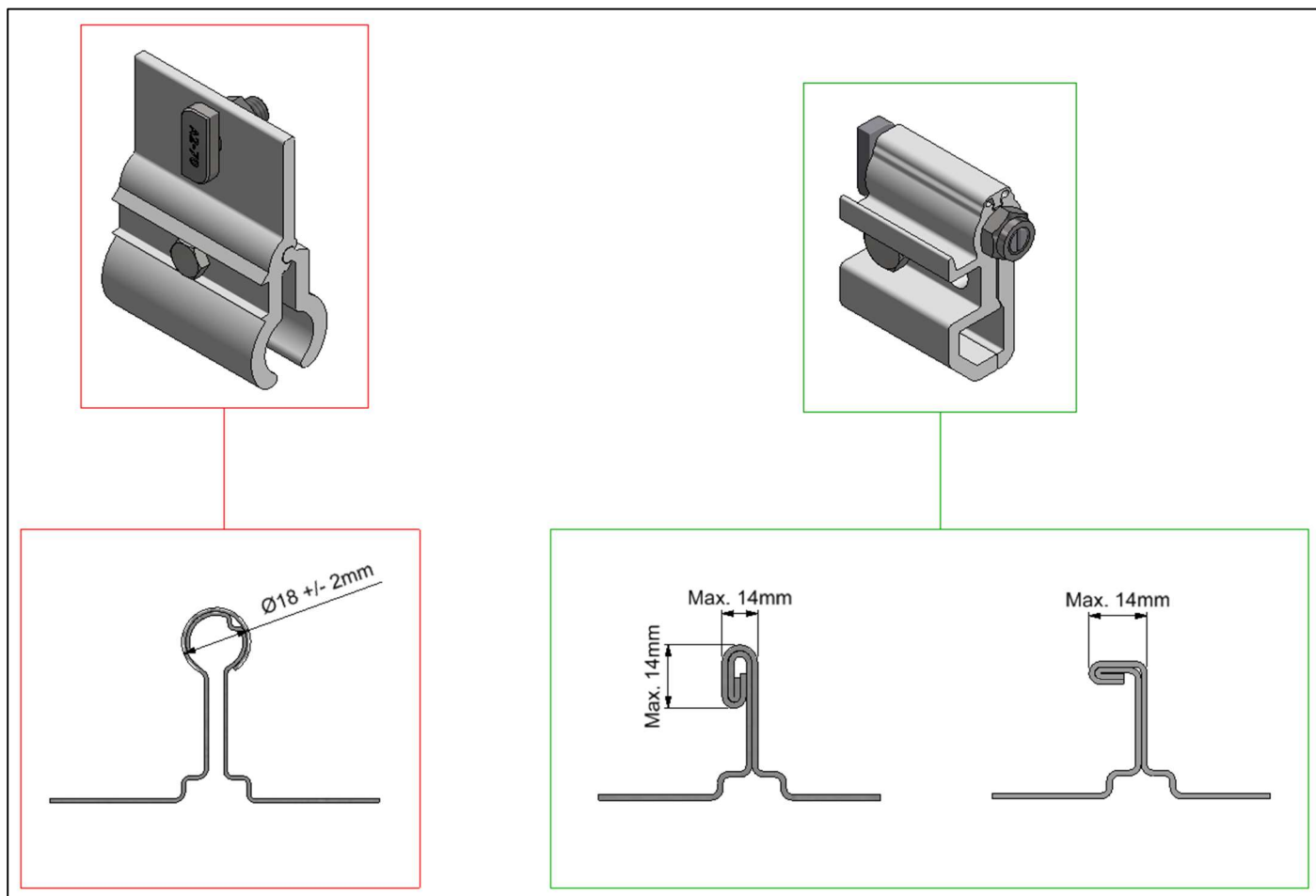

Always check the standing seam type to see which mounting clamp is required, also check if the standing seam fits the measurements above.



Please note! The aluminium standing seam clamps are not compatible with copper standing seam roofs. Please contact Van der Valk Solar Systems for other solutions.

VAN DER VALK



Mounting 'round' standing seam clamp

Place the clamp over the standing seam and fasten the lower bolt.

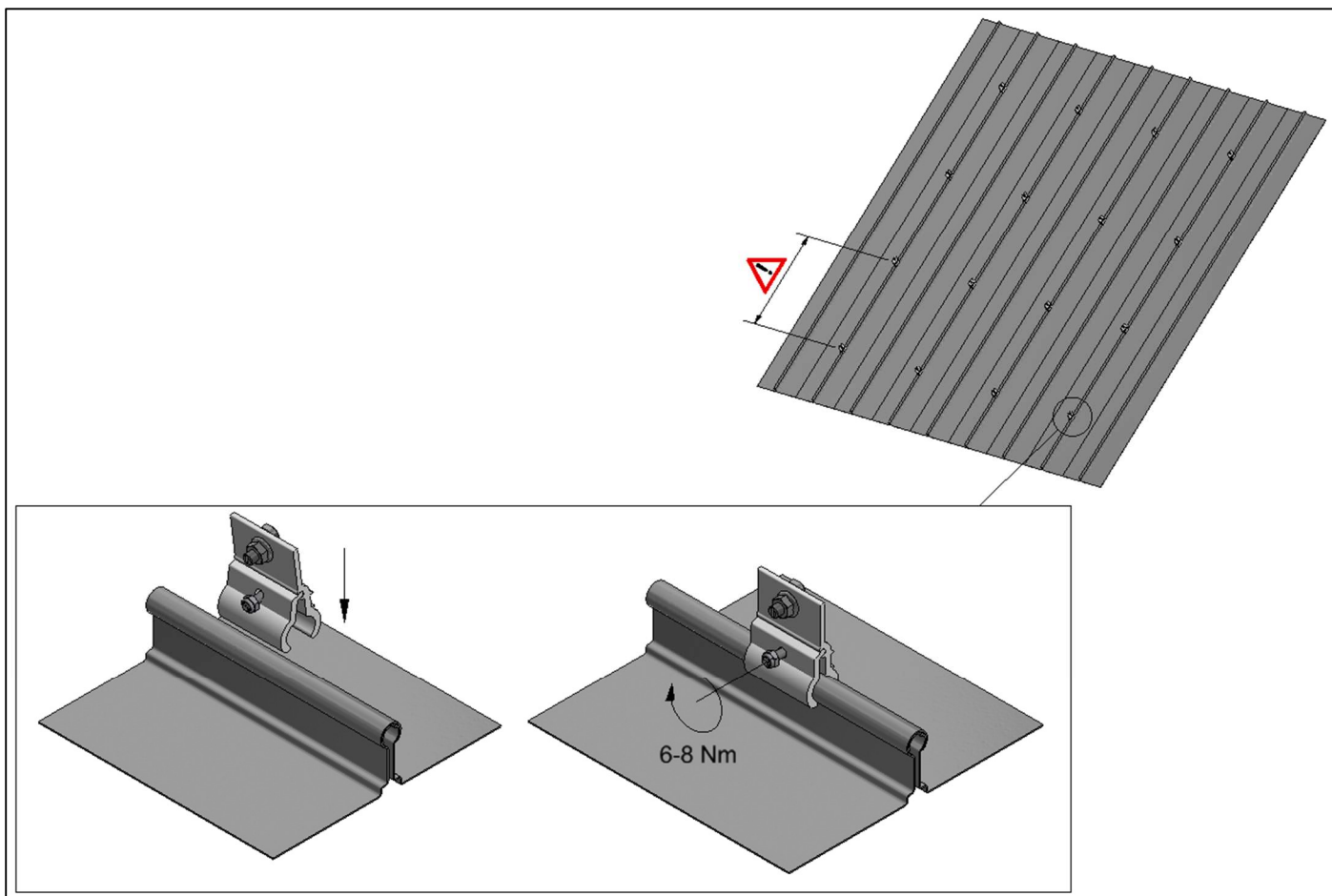

Check the outcome of the calculation for the maximum distance between the mounting clamps and the required amount per profile.

Mounting standing seam straight clamp

Place the clamp over de standing seam and fasten the clamp with the bolt+nut.

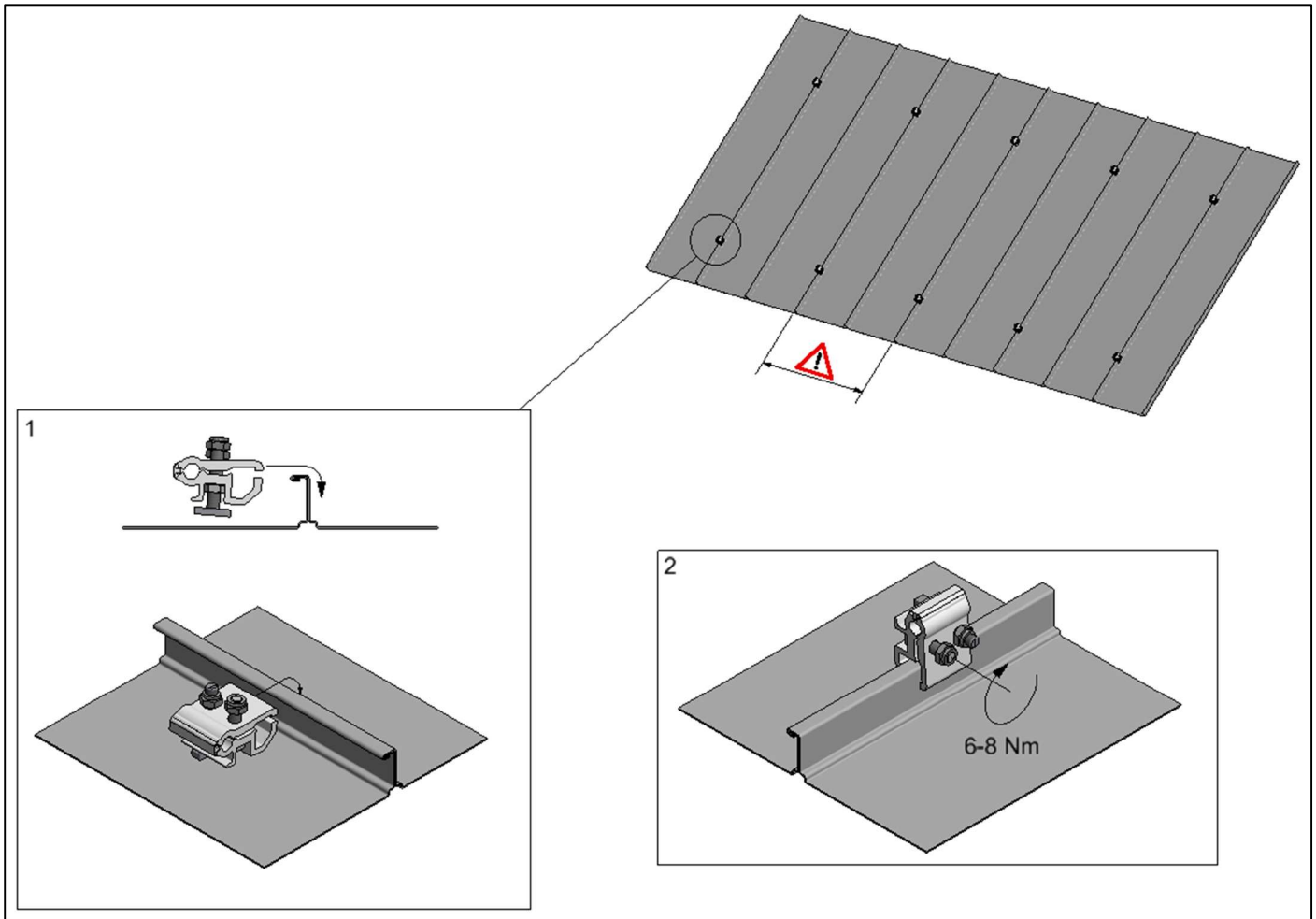

Check the outcome of the calculation for the maximum distance between the mounting clamps and the required amount per profile.

Mounting aluminium profiles

The mounting of the aluminium profiles is for all mounting clamps the same. For the rest of the manual the standing seam straight clamp will be shown, the workflow when using the different mounting clamp will remain the same.

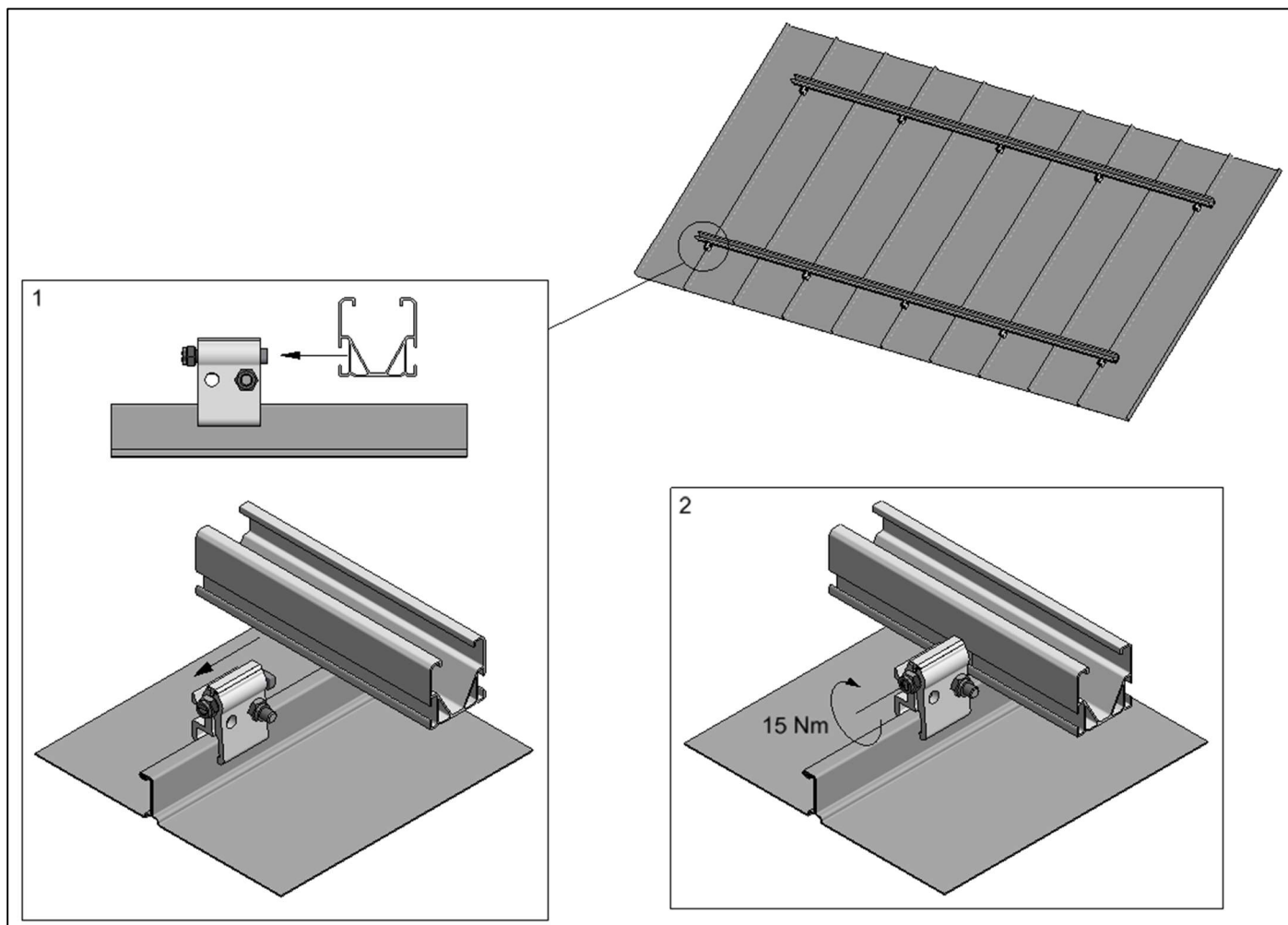

The aluminium profiles are mounted to the clamps with the hammerhead bolts. The hammerhead bolts are placed in the slots of the profiles. When all bolts are placed in the profile everything is fastened with the locknut of the clamp. (max. torque is 15Nm).

Dilatations

The coupled system has to be dilatated after certain measurements, this needs to be done because of the thermal expansion/contraction. For the aluminium profiles this measurement is 30 meters. The minimal dilatation distance between the profiles is 150 mm.

When the profiles are horizontally mounted it is important that the profiles are placed on the upper side of the clamps. If the pre-mounted hammerhead bolt is facing down it should be changed so it is facing up.

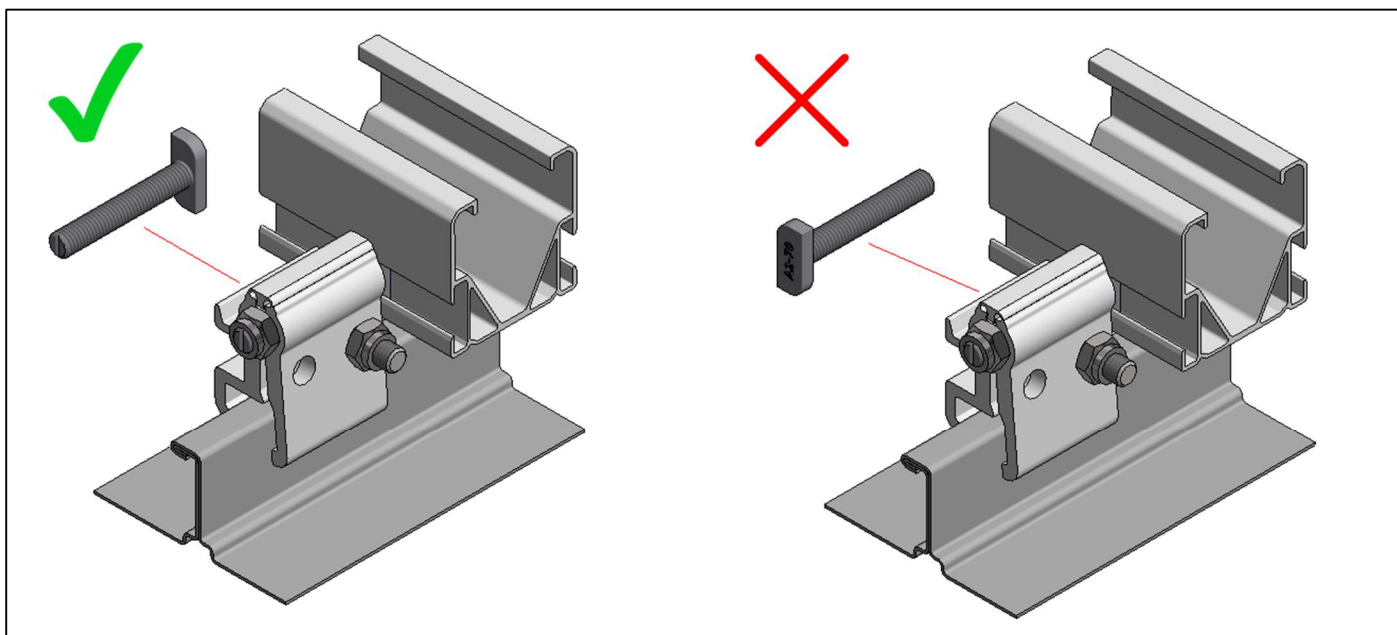

When fastening the bolt/nut of clamps it is important that the hammerhead bolt is correctly placed in the aluminium profile. If the hammerhead bolt is not in the profile properly the aluminium profile can come loose (see image below).

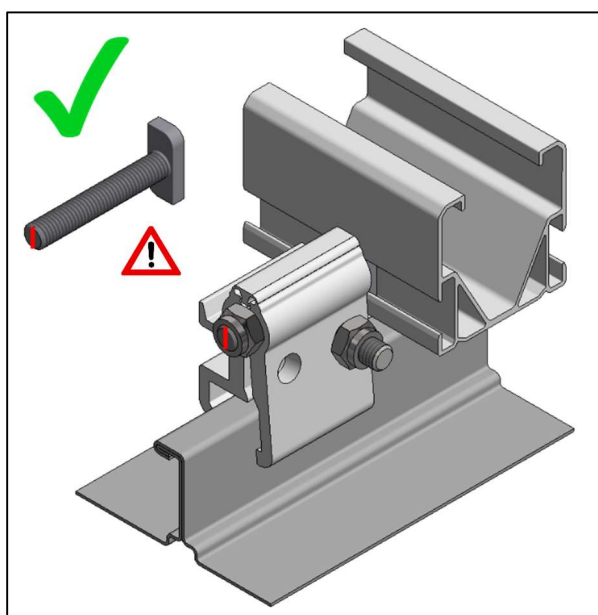
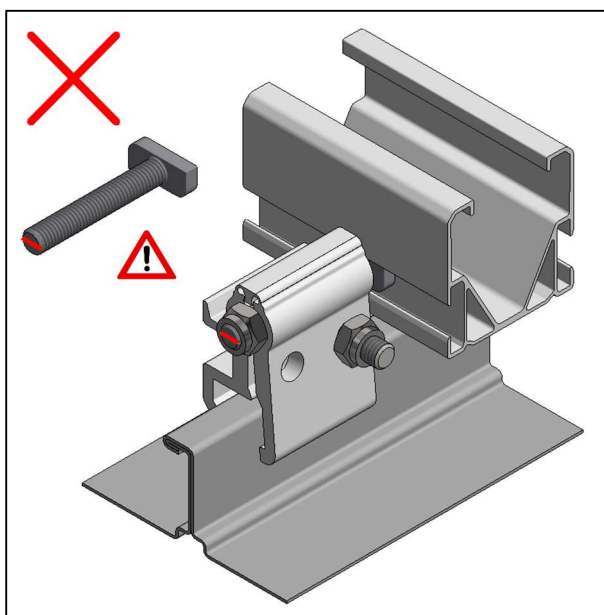

The groove on the hammerhead bolt corresponds with the orientation of the bolt head. Make sure the bolt is always mounted correctly.

Coupling aluminium profiles

The aluminium profiles can be coupled together with the coupling pieces (724863). Each coupling piece has 4 hammerhead bolts, 2 for each end of the profile. Make sure all hammerhead bolts are in the profiles and fix the lock nuts when ready. (max. torque is 15 Nm)

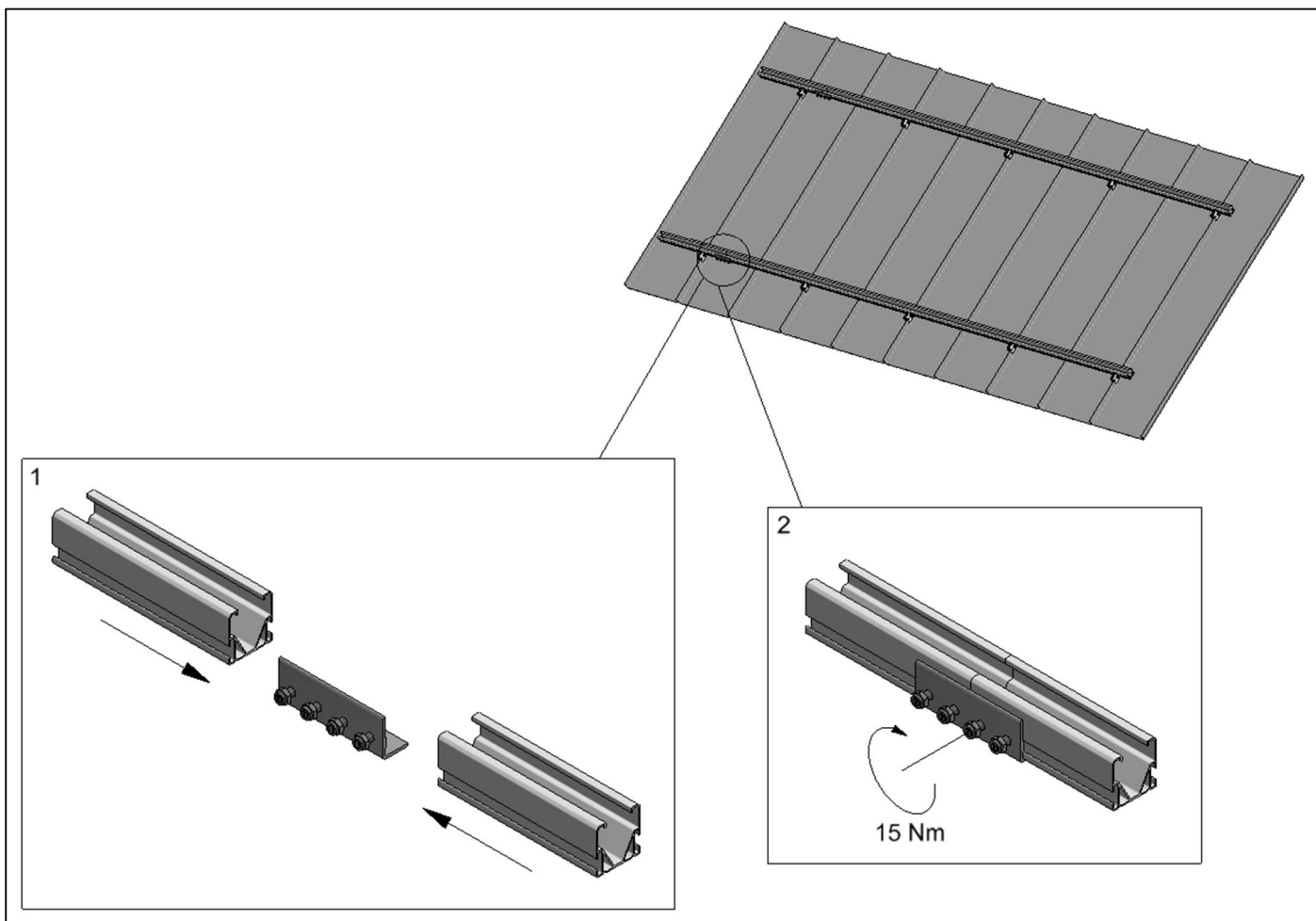

When fastening the bolt/nut of the coupling it is important that the hammerhead bolts are correctly placed in the aluminium profile. If the hammerhead bolts are not in the profile properly the aluminium profile can come loose (see image below).

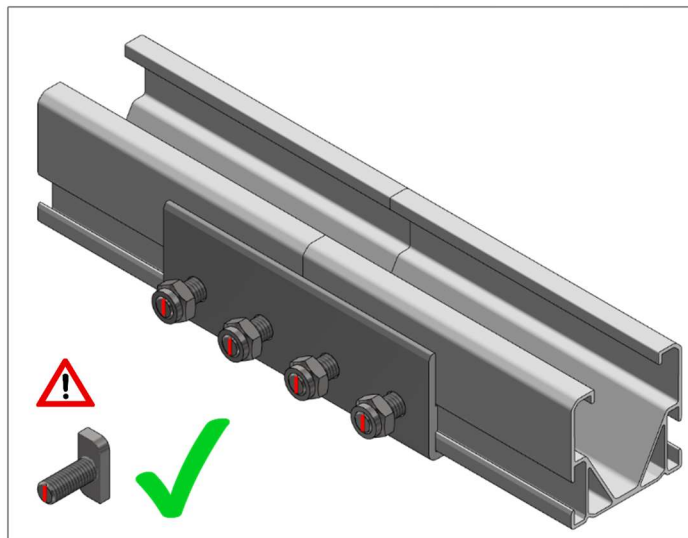
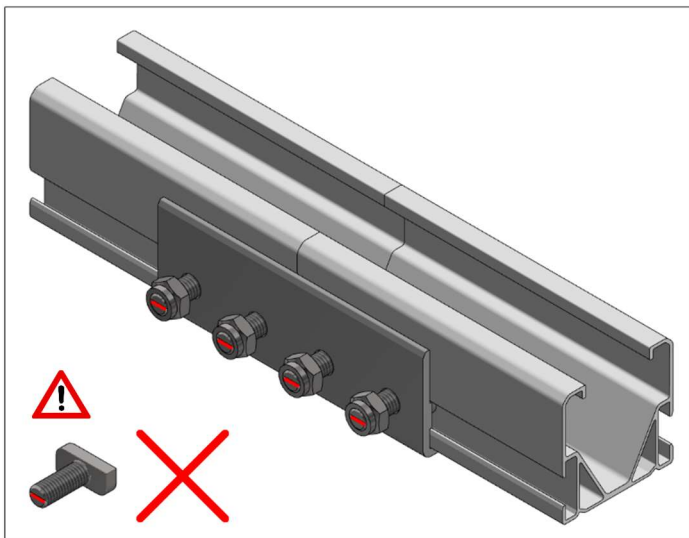

The groove on the hammerhead bolt corresponds with the orientation of the bolt head. Make sure the bolt is always mounted correctly.

Mounting end clamps

Each end of the panel row is fixed with the end clamps (721552). The end clamps have a range for the panel thickness from 28-50 mm.

The panel clamp can be mounted by turning it clockwise in the aluminium profile.

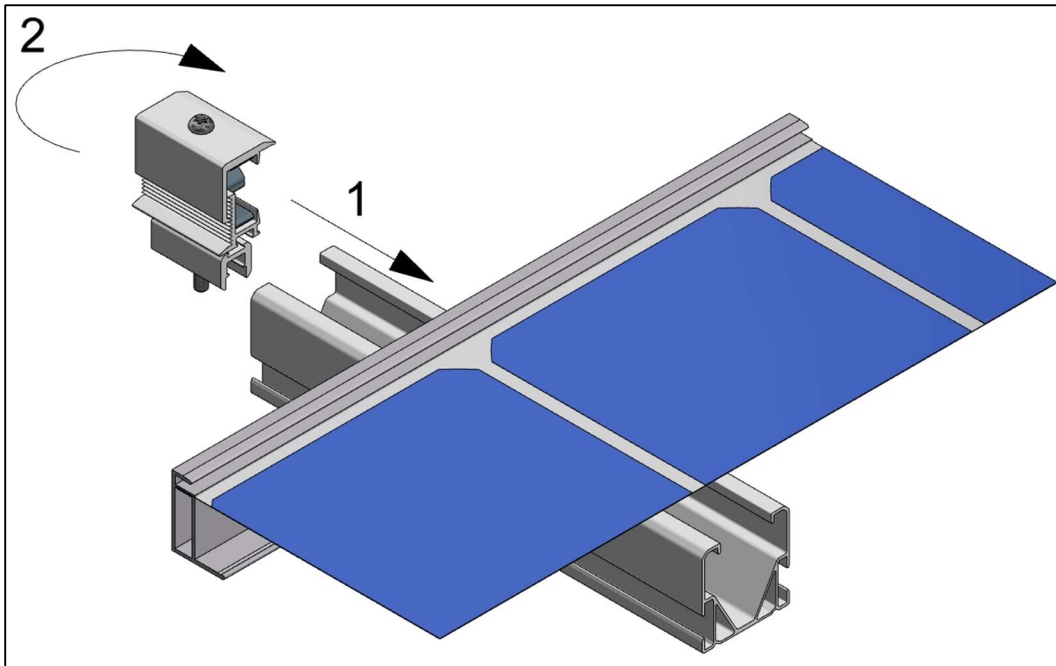

Once the end clamp is in the profile set the end clamp to the correct height. This is done by putting the top cap into one of the slots. (see below)

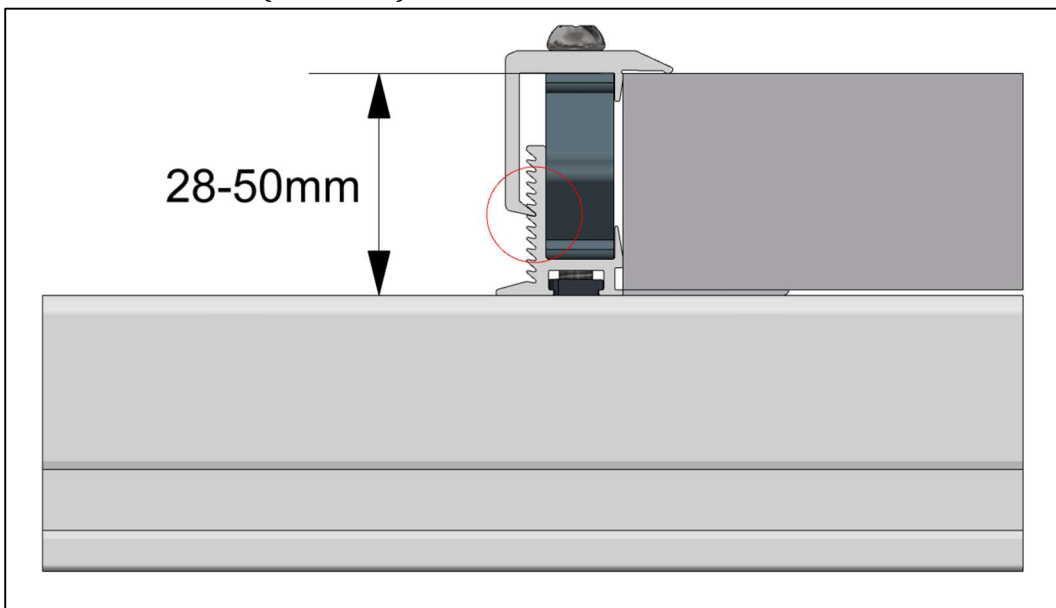

Use the bolt on top of the clamp to fix the end clamp. (torque 6-7 Nm)

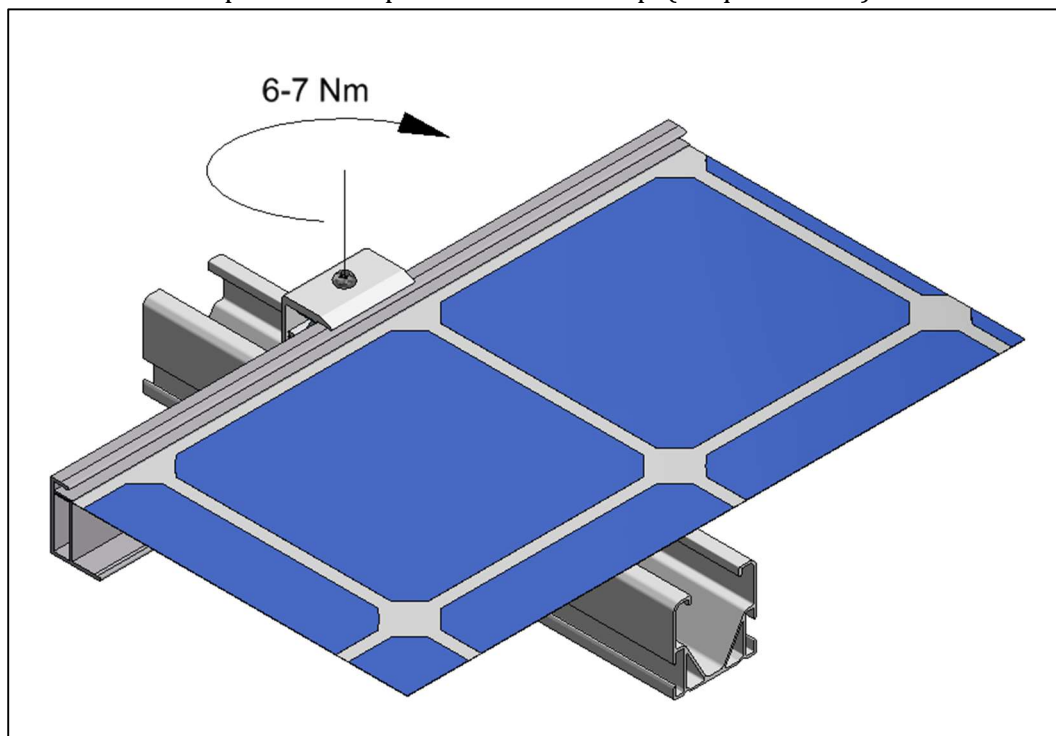

Mounting panel clamps (middle)

The middle clamps are mounted the same as the end clamp, only the height of the clamp is not set to a certain height.

Place the middle clamps in the profile and make sure the panels are pushed together. The panels have to be placed against the middle clamps until they can't go further.

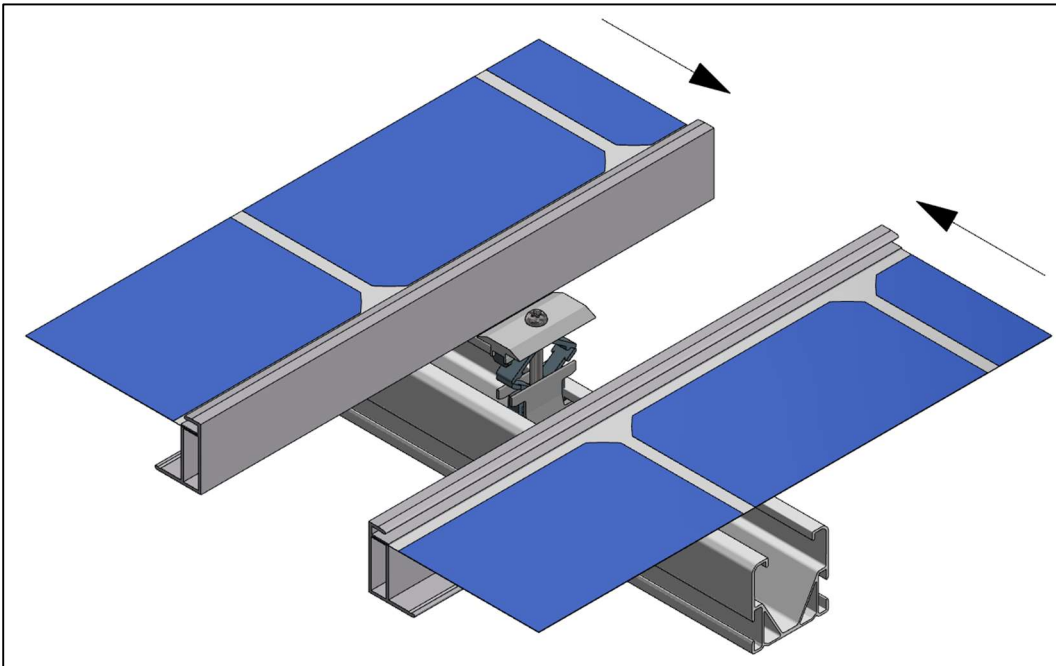

Once the panels and middle clamps are in place they can be fixed with the bolt of the middle clamp. (torque 6-7 Nm)

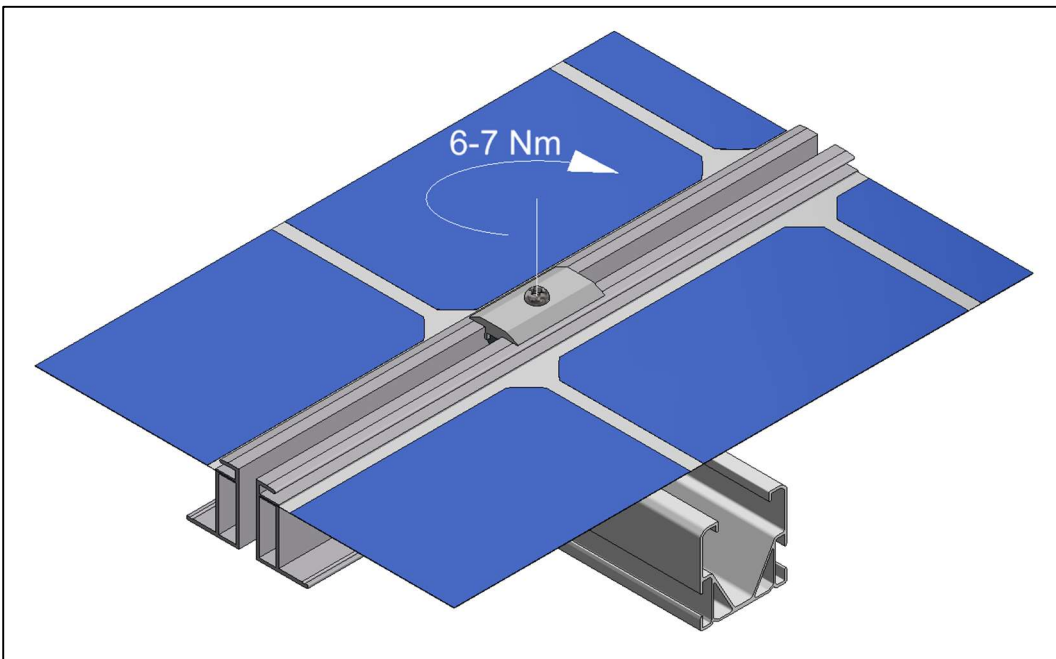

Cable clamps

For the pitched roof clamp systems there are 2 types of cable clamps available (standard). These cable clamps can be helpful with your cable management.

Small cable clamp (732001)

The small cable clamp can be mounted to the aluminium profile or the solar panel. The small cable clamp can fit 1 cable.

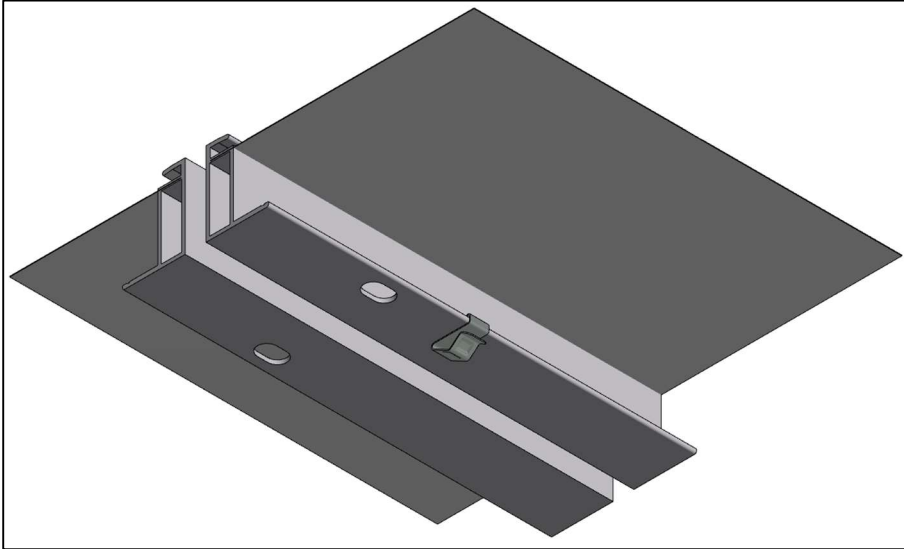

Cable clamp to panel frame

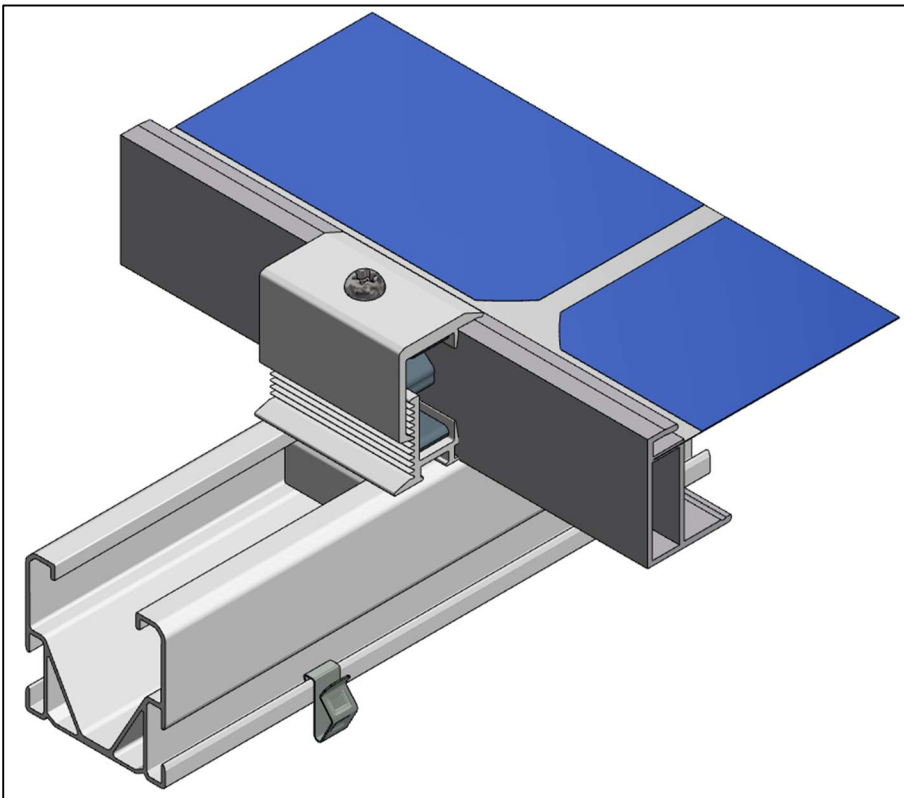

Cable clamp to aluminium profile

Large cable clamp (732005)

The large cable clamp can be placed on the aluminium profile. The larger cable clamp can hold multiple cables depending on the size.

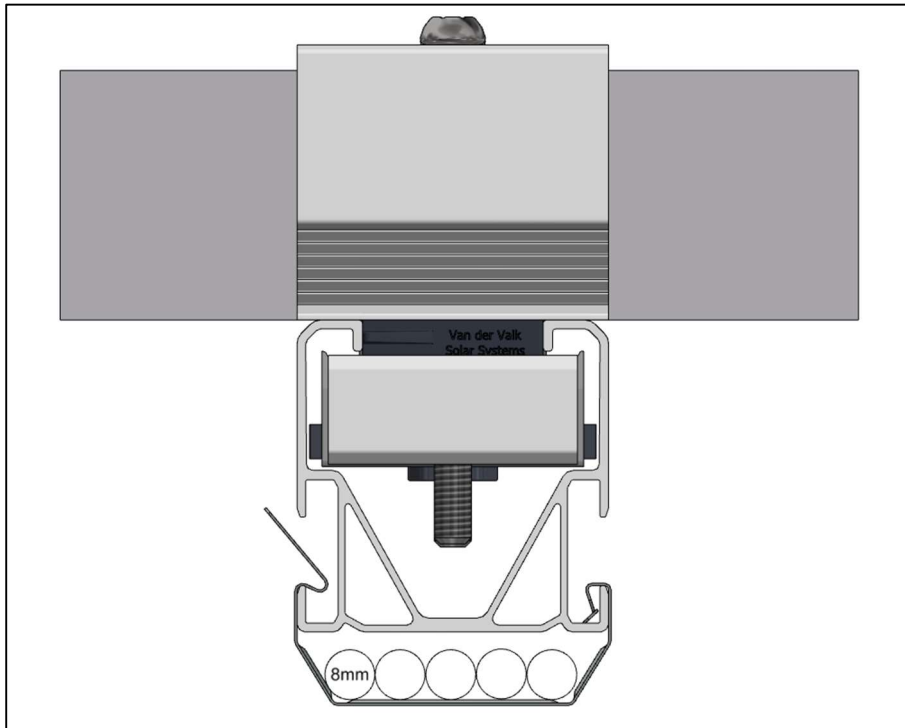

Mounting optional products

The pitched roof system has a variety of optional products that can be used to optimize the system. Down below is explained what each product does and how it should be mounted.

Black end cap (739052)

The black end cap is used in the 'semi-black' or 'full-black' systems. The end caps are placed over the aluminium profiles. This gives the system a better appearance overall.

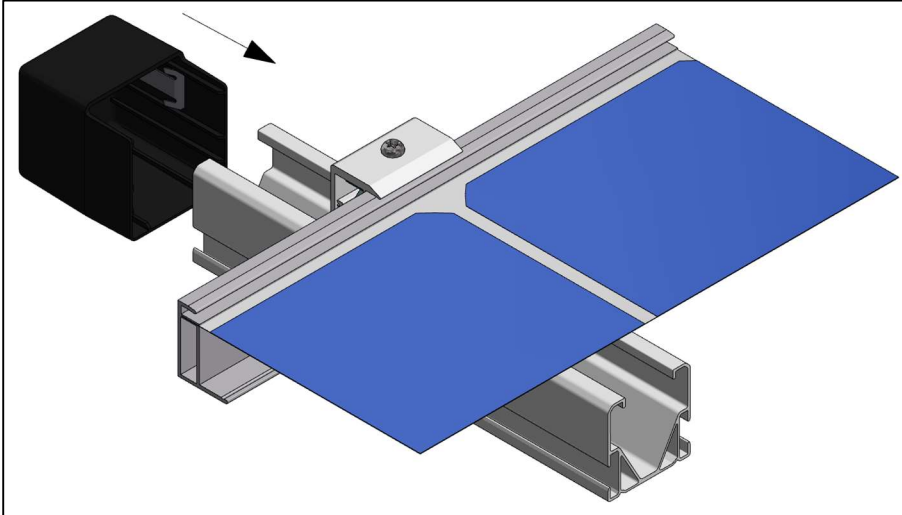

Micro inverter clamp (774223)

The micro inverter clamp is used to fix the micro inverter to the aluminium profile.

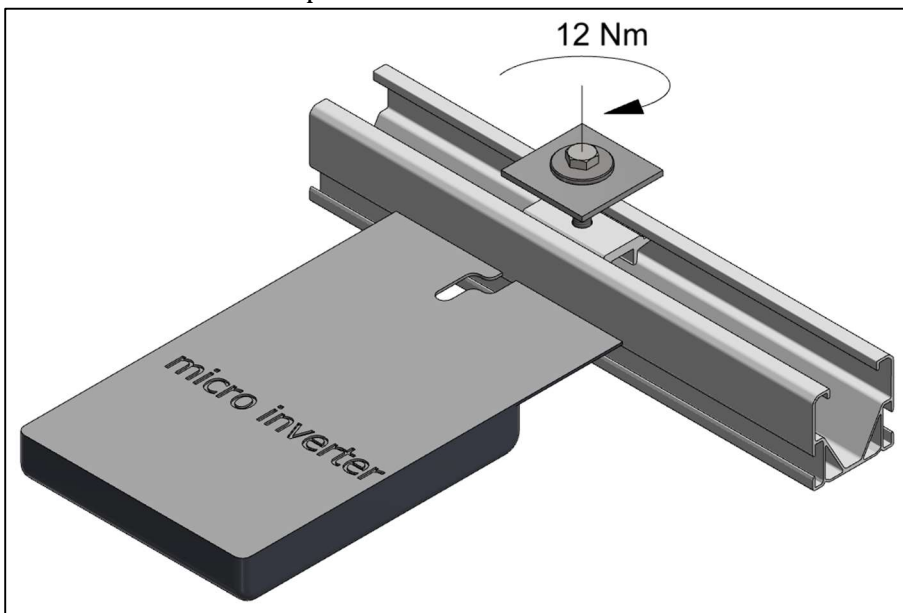

Panel alignment pin (733020)

The panel alignment pins can be mounted to the frame of the solar panel. Once the pins are fixed to the frame the panel can easily be hung to the aluminium profile. This gives the option to mount the panel clamps without being bothered by the alignment of the panel.

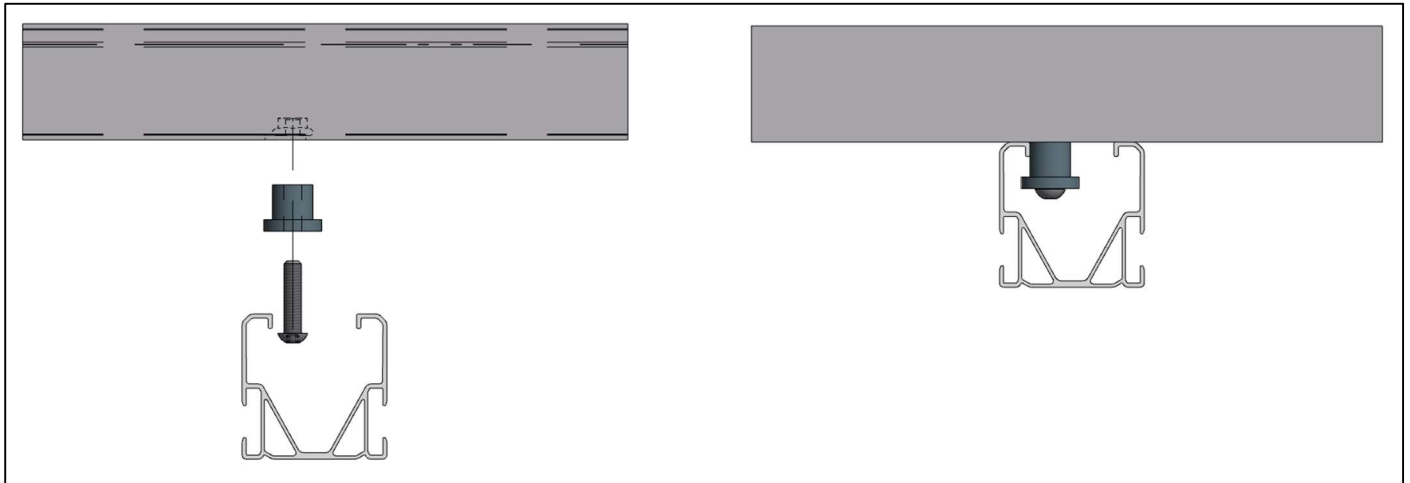

Van der Valk Solar Systems

Van der Valk Solar Systems is since 2009 one of the fastest growing companies in the solar industry and focuses entirely on the development and production of solar mounting systems for pitched roofs, flat roofs and open fields. Van der Valk Solar Systems also has an office and warehouse in the UK, offices in Sweden and Spain and is currently active in 13 countries.

Our mounting systems are developed and produced in our own factory in the Netherlands and stand out thanks to their broad area of application, the very short time in which they can be installed, and the high quality. They are developed according to the latest Eurocodes and therefore comply with the requirements defined for solar systems by banks and insurance companies.

Van der Valk Solar Systems is part of family-owned company Van der Valk Systemen, which has been a household name in the field of moving systems and mounting components since 1963.

Our shared industrial complex consists of 20,000m² of offices and factory spaces. Here we use modern machinery and the latest technologies to quickly and accurately develop, manufacture, and test products and systems.



Solar mounting systems & cable management



Flat roofs



Pitched roofs



Cable management

CONTACT DETAILS | DEVELOPER AND PRODUCER OF SOLAR MOUNTING SYSTEMS



Van der Valk Solar Systems + International

Westernesse 18 - 2635 BG Den Hoorn, The Netherlands
+31 174 25 49 99
sales@valksolarsystems.com

Valk Solar Systems UK + IE

+44 1304 89 76 58
sales@valksolarsystems.co.uk

Valk Solar Systems Ibérica

+34 699 326 544
ventas@valksolarsystems.es

Valk Solar Systems Nordics

+46 7 24 41 60 82
sales@valksolarsystems.se

www.valksolarsystems.com



Van der Valk Solar Systems International



valksolar



Van der Valk Solar Systems International



Valksolar